

USER'S GUIDE

Installation & Operation
Instructions

Pump Station Level Controller
Model PSL
Series B.11

Note: This page has been left blank intentionally.

INDEX

Bench Test 4
Connections 4
RS-232C Serial Output 5
Keypad System 6
Menu - Flow Chart 6
Display Units 8
Echo Confidence 8
Relay Status 8
Password 9
Units / Mode 9
Calibration- for Level Control 10
4/20mA Current Loop Offset 11
Damping 11
Rejection Time 11
Relay Parameters 12
Special Functions 14
Sensor Mounting Location 17
Enclosure Installation 19
Error/Warning Messages 20
Troubleshooting 21
Installation Considerations in Noisy Environments 23
Applications Hotline 25
Product Return Procedure 26
Warranty 27
Appendix A - Options 28
Appendix B - Applications Background 34
Conversion Guide 35
Specifications 36

IMPORTANT NOTE: This instrument is manufactured and calibrated to meet product specifications. Please read this manual carefully before installation and operation. Any unauthorized repairs or modifications may result in a suspension of the warranty.

Available in Adobe Acrobat pdf format

QUICK BENCH TEST:

Connect Sensor as shown below, then apply Power. When properly connected a soft clicking can be heard from the sensor and figures will show on the large LCD display. Test operation of the PSL by holding the sensor steadily and aiming at a flat, stable target 16 to 30" (50 to 100 cm) away from the end of the sensor. Allow a few seconds for the PSL to lock onto the target before displaying its distance. The PSL will now display distance in ft or cm (factory calibration).

Note: The PSL will not detect targets beyond user entered MaxRg.

CONNECTIONS:

POWER INPUT: The standard model requires AC power input between 100-130 VAC 50/60Hz (2 amp fuse is recommended). No adjustments are necessary for any voltage in this range. Optional 230VAC requires power input between 200-260 VAC 50/60Hz. (See OPTIONS section of this manual for connection of optional 12VDC or 24VDC power input).

IMPORTANT NOTE: To comply with CSA/NRTL standards, AC power input and relay connection wires must have conduit entry to the instrument enclosure.

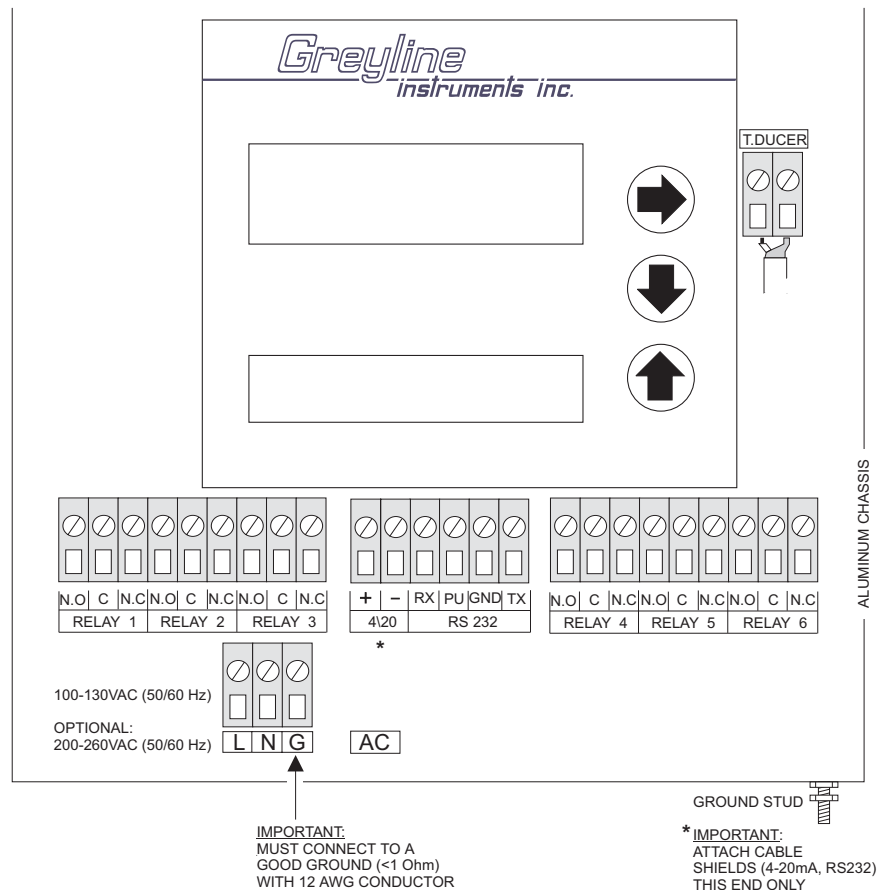

RS-232C SERIAL OUTPUT

Format: 8 Bits, 1 Stop Bit, No Parity. (Baud rate may be changed under the SPECIAL FUNCTIONS menu. Factory default is 19200 baud).

Output Connector is DB9-Female. Use the cable supplied for connection to a PC Computer. Use the cable, optional DB25F/DB9M adaptor and optional NM-25MM "null modem" for connection to a modem.

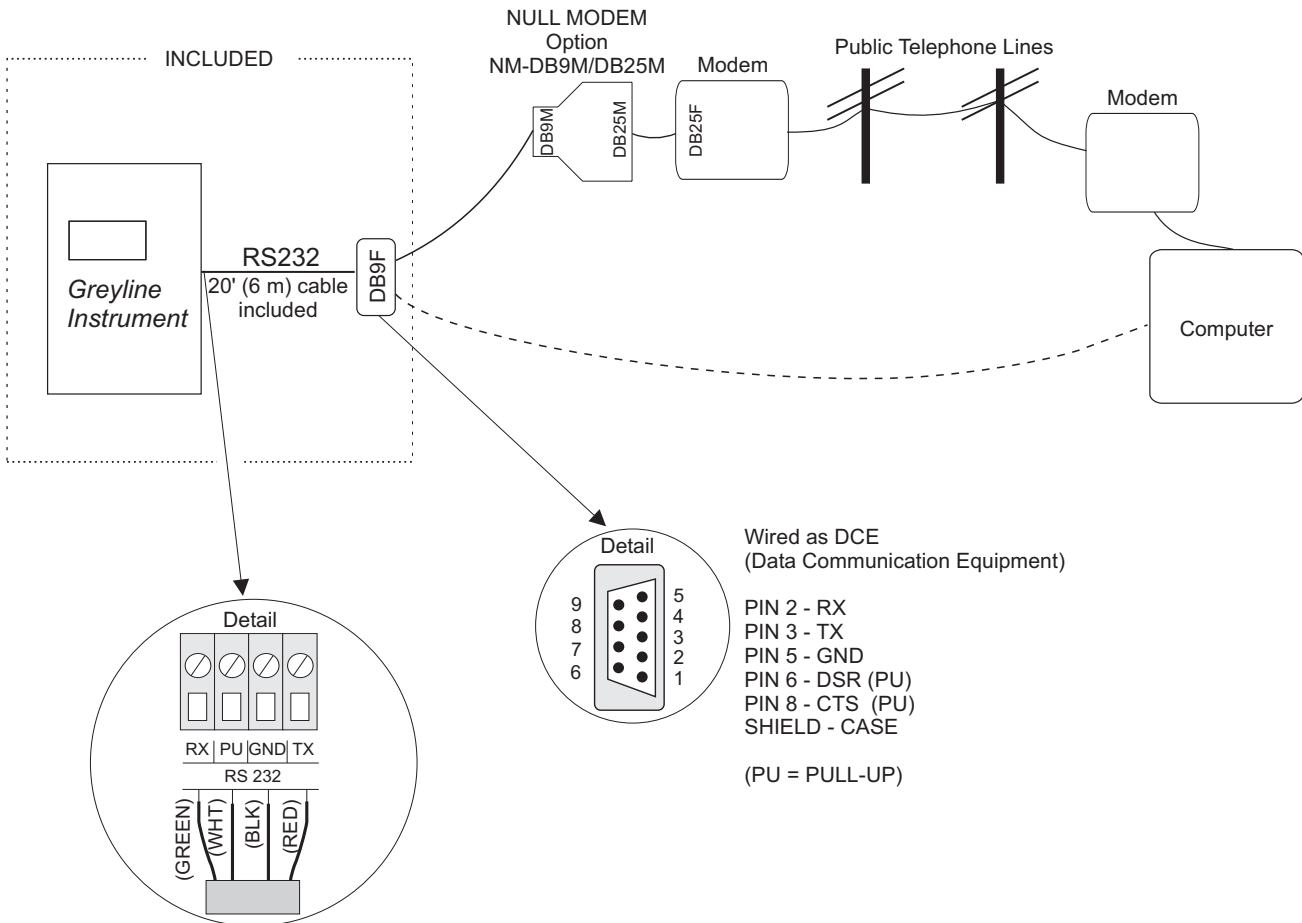

KEYPAD SYSTEM

The PSL has a simple 3-button calibration system. Operating and calibration modes are shown on the 16-digit alphanumeric display. The keypad is used to move around the menu to calibrate the PSL, and to view operating mode and functions. A beep is sounded as each key is pressed. If the keypad is not used for 10 minutes, the PSL will automatically go to DISPLAY UNITS mode (scrolling display). Use the keypad to explore the Menu and become familiar with its features.

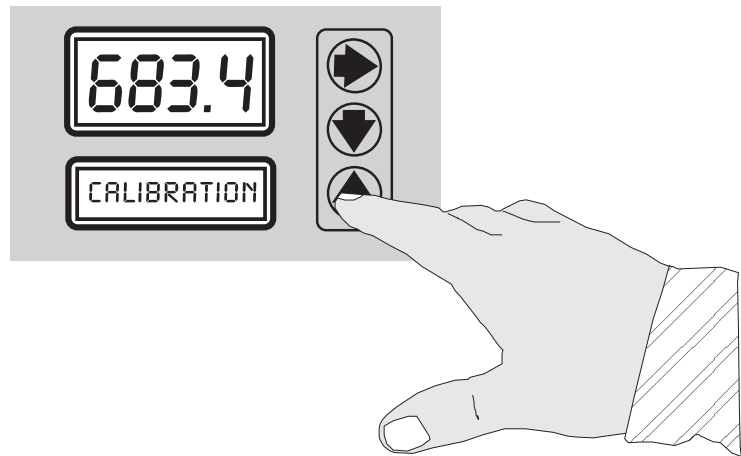

MENU - FLOW CHART

The following diagram shows part of the PSL Menu system. Arrows show the three directions to leave a box. Pressing a corresponding keypad arrow will move to the next box in the direction shown. Move the cursor (or underline) under numerals to increase or decrease the number with the ↓ ↑ keys.

At the bottom of each Menu column is a STORE? YES box. To store the calibration values permanently (even through power failure), move the cursor under YES and press the ↓ or ↑ key. If the ↓ key is pressed with the cursor under STORE? no changes will be stored and the system will return to the top of the Menu column.

PSL MENU

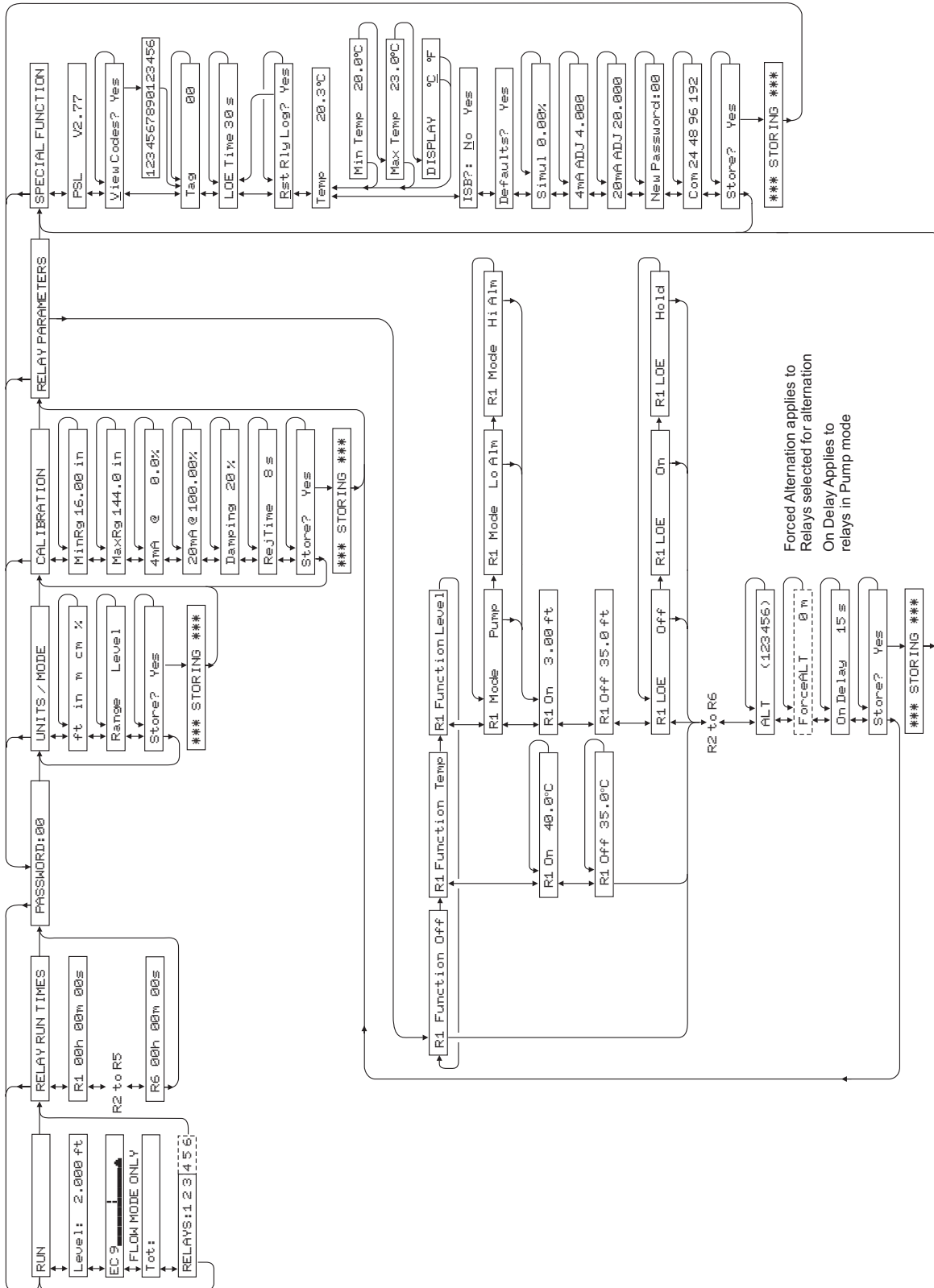

DISPLAY UNITS

A scrolling display shows the units selected from the units selection column, the mode of operation (Range or Level), the maximum scale value for the large numeric display, the Relay Statuses and the temperature measured at the sensor.

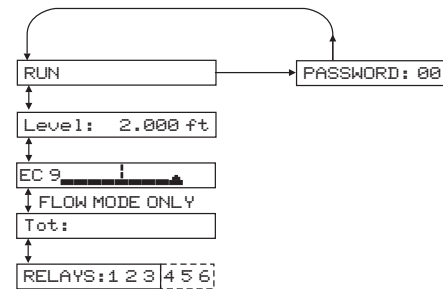

LEVEL READING

From RUN use ↓ to view the level measured by the instrument.

ECHO CONFIDENCE

Echo Strength is automatically adjusted by the PSL in response to operating conditions in the application. As long as the Echo Strength Arrow passes to the right of Minimum Marker the PSL is receiving echoes normally.

From RUN use ↓ to get to the Echo Confidence display, EC.

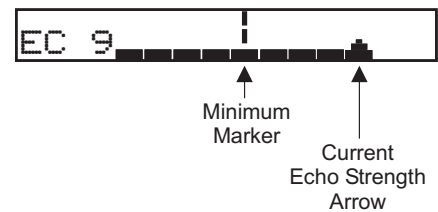

RELAY STATUS

From ECHO CONFIDENCE use ↓ to continuously display the 6 Relay states. As each relay is energized the relay number is highlighted.



Press ↓ or ↑ keys to return to DISPLAY UNITS.

RELAY RUN TIMES

The PSL will display relay run times directly on the alphanumeric display. Press → from DISPLAY UNITS to get to RELAY RUN TIMES then press ↓ to view the Relay Run Time Report. Each relay Run Time is listed in hours, minutes and seconds.

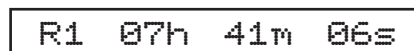

The password - protected run time log can be reset by going to SPECIAL FUNCTION and ↓ to Reset Log? Yes

PASSWORD

The password (a number from 00 to 99) prevents unauthorized access to the CALIBRATION MODE.

From DISPLAY UNITS press → past RELAY RUN TIMES to get to PASSWORD.

Press → to place the cursor under the digits and ↓ or ↑ to change the number.

Factory default Password is 00. A new password can be stored by going → to SPECIAL FUNCTIONS and ↓ to New Password.

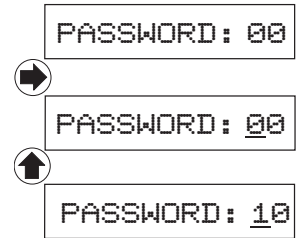

UNITS / MODE

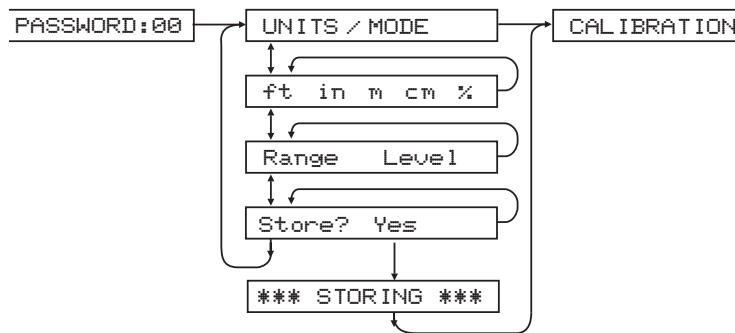

Press → to UNITS/MODE, then ↓ to Range Level. Use → to select the operating mode of the PSL.

Range this mode displays distance from the sensor to the target or liquid surface like a tape measure. Range mode is useful to measure the exact distance from the sensor to the zero level during calibration, or to monitor “outage” or free space in a tank.

Level1 this is the most common mode and it is used to measure pump station level or tank inventory

Press ↓ from Range or Level mode to ft in m cm %

Press → to move the cursor under the required measurement units:

- ft - feet
- in - inches
- m - meters
- cm - centimeters
- % - percent

Press ↓ to Store and → to Yes. Then press ↓ or ↑ to store your UNITS/MODE selections.

CALIBRATION
- for Level Control and Inventory Applications

1. Before starting the calibration determine:

- a) MAX RANGE = _____
(Maximum range = distance from Sensor to Zero level)
- b) MAX LEVEL = _____
(Maximum level of product being measured)
- c) MIN RANGE = _____
(Distance from sensor to Max Level)
Minimum range = MAX RANGE - MAX LEVEL
(*must be at least 16" / 406.4 mm*)

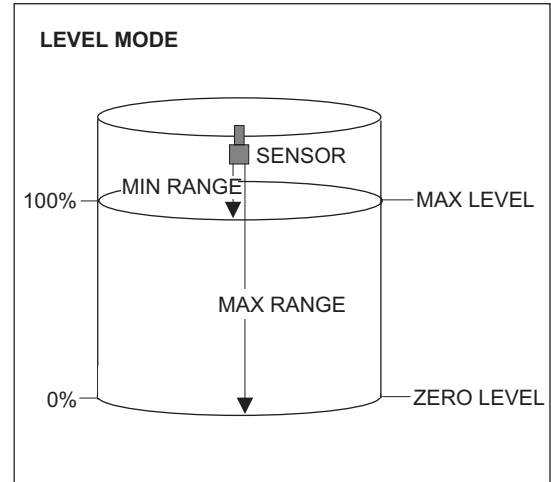

2. Check the maximum range with the sensor installed by:

- a) Use \rightarrow to get to UNITS/MODE then \downarrow to get to RANGE, then STORE? \rightarrow YES
(NOTE: liquid must be at zero level)
- or
- b) Carefully measure distance from sensor to zero level with tape measure.

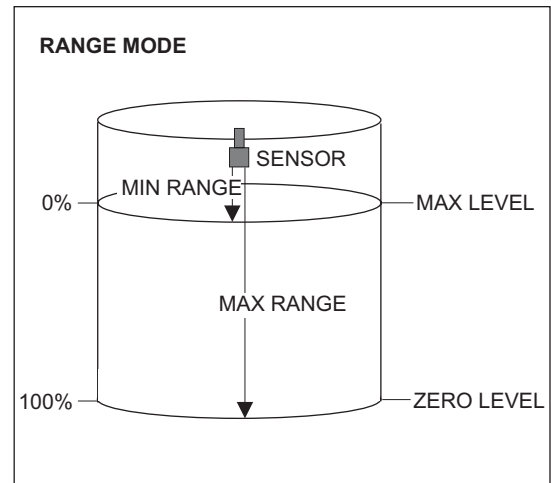

MinRg - Minimum Range

At CALIBRATION

- Press **↓** to get to MinRg
- Press **→** to move the cursor under the digits
- Use **↓** or **↑** to set the minimum range
Note: MinRg must be ≥16" (40.64 cm) with standard PZ34 sensor.
- Press **→** to return to MinRg

MaxRg - Maximum Range

Repeat as for MinRg

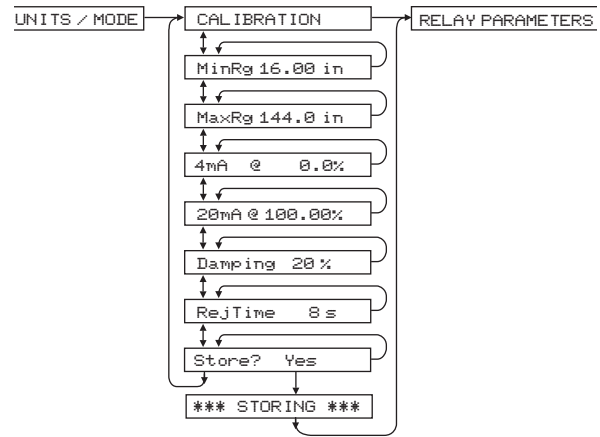

Note: The PSL will not detect targets beyond user entered MaxRg.

4/20mA Current Loop Offset

Some applications may require the 4-20mA output to be offset so that 4mA or 20mA corresponds to a Level or Range other than Zero and Full Scale.

4mA @ - use **↑** and **↓** to set % output for 4mA. It is adjustable from -5% (3.8mA) up to 15% lower than the 20mA setting. Adjustment resolution is 0.05% (0.01mA).

20mA @ - use **↑** and **↓** to set % output for 20mA (down to 15% greater than the 4mA setting and up to 300%). Adjustment resolution is 0.05% (0.01mA).

Damping

Minimum damping allows fast response to level changes. Increasing damping slows the PSL’s response to level changes and is ideal to smooth the display and outputs in turbulent conditions. Damping value is shown in Percent. Some experimentation may be required to select the optimum damping value. A value of 20% is recommended for most applications. For fast level changes (up to ½ inch/sec - 13 mm/sec), a Damping value of 1% is recommended. Maximum is 99%.

Rejection Time (RejTime)

Rejection Time adjustment is a powerful PSL feature to suppress false echoes and the effects of transient targets such as agitators or splashing. Rejection Time is shown in seconds. The time value represents the number of seconds the PSL must receive repeated echoes from a new target before indicating its level on the display and outputs. The factory default is 8 seconds and should be ideal for most applications. Decreasing this value allows the PSL to respond more quickly to fast level changes, and increasing the time value allows the PSL to reject false echoes from slow sweeping agitators, tank filling streams, splashing, severe turbulence and steam. Minimum setting is 1 second (for fast level changes up to ½ inch/sec - 13 mm/sec). Maximum setting is 85 sec.

RELAY PARAMETERS

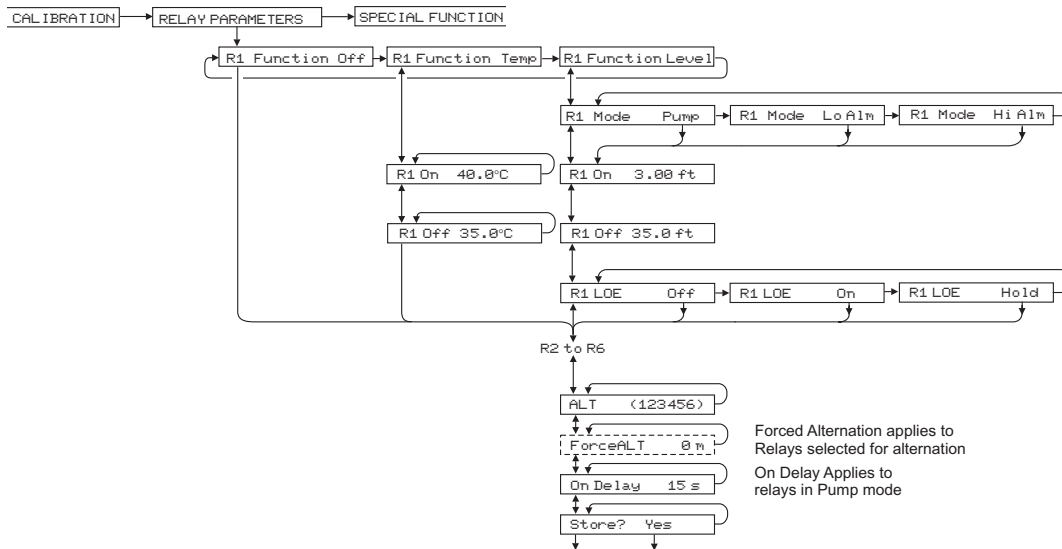

Relay Function

Use ➡ to select the Relay Operational function:

- Off Relay is selected as Off (de-energized) at all times.
- Temp Relay is selected as temperature alarm (air temperature measured at the sensor).
- Range/Level Relay is selected for Range / Level Control for pump stations, wet wells and Tank Inventory.

Relay Modes

Use ➡ to select the Relay mode for Range / Level function.

- Pump Select Pump mode for pump up, pump down and valve control applications. Relay operates with separate ON and OFF set points.
- Lo Alm Select Lo Alm for low level alarms. Relay energizes at the On set point and de-energizes at On set point + 2% of the span
- Hi Alm Select Hi Alm for high level alarms. Relay energizes at the On set point and de-energizes at On set point - 2% of the span.

Relay Set Points

- On Set Point in selected units at which relay energizes
- Off Set Point in selected units at which relay de-energizes.

LOE (Loss of Echo) Action

Each relay can be programmed to go Off (de-energize), On (energize) or Hold (hold state) when the PSL echo is lost for fail-safe operation. To calibrate a relay for echo loss alarm only, set the relay On

and Off set points to exactly the same value, and then set LOE to On mode. The relay will now energize only when an echo loss condition occurs.

Use **➡** to select the LOE action

Relay / Pump Alternation

Pump alternation allows even pump wear in pumping station applications. Any Relay selected for pump control can be programmed for automatic pump alternation.

ALT (- None -) Indicates that no relay has been programmed for automatic alternation

ALT (1 2 3 4 5 6) Press **➡** to place cursor (underline) under the relay number to be programmed for alternation and press **⬇** or **⬆** to highlight number. Repeat until all relays to be programmed are highlighted.

Note: Alternating pumps must have different On setpoints to alternate correctly, otherwise alternating pumps will turn On at the same time.

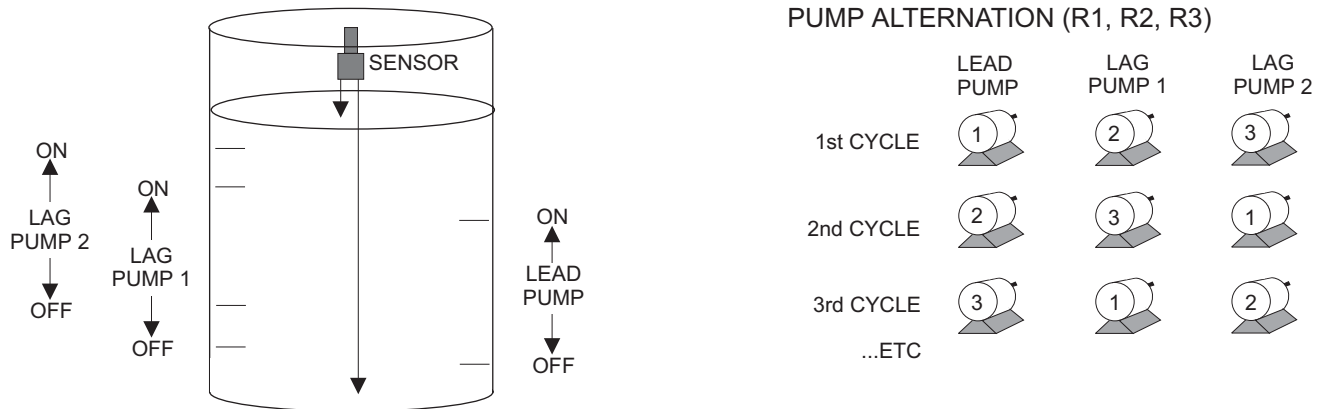

Forced Alternation (Time Out)

The Forced Alternation time out feature is designed for pump control applications with automatic alternation. It operates when the lead pump (pump with the lowest On set point) stays on too long and prevents pump alternation.

Force ALT Set the forced alternation time out in minutes from 0 - 9999. If set to 0 minutes forced alternation is disabled.

Relay / Pump On Delay

The Relay/Pump On Delay feature allows the user to program a time delay so that relays/pumps DO NOT energize/start at the same time, to avoid power surges and power overloads.

On Delay Set the Relay/Pump On time delay in seconds from 0 - 99.

SPECIAL FUNCTIONS

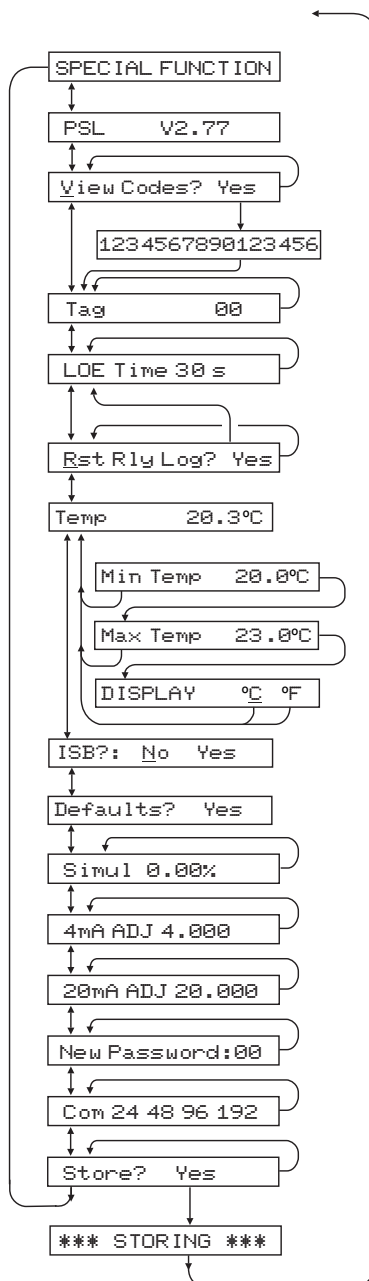

PSL Version	Shows software version installed
View Codes? Yes	Select <u>Y</u> es and then ↓ to display an instrument performance code. Faults detected by the instrument are stored in the code and will be requested by Greyline if you call for service or assistance.
Tag	Enter Instrument Tag number (0-999)
LOE Time	Select Loss Of Echo time (10-60 secs) - LOE is the time that the PSL waits after losing consecutive echoes to take LOE action (and to display "ECHO LOSS"). When Echo Loss occurs, the PSL display, totalizer (in flow mode) and 4-20mA will hold at the last reading until a new echo is received. PSL Relay's response to Echo Loss can be individually programmed in the Relay Parameters menu.
Rst Rly Log? Yes	Select <u>Y</u> es to clear the Relay Run time log to start a new log.
Temp 25.0°C	Indicates current temperature at the sensor head. Press ➡ to MIN. T and ➡ to MAX. T to display the minimum and maximum temperatures the PSL has sensed.
ISB?: No Yes	Select <u>Y</u> es only when the instrument is equipped with an optional Intrinsic Safety Barrier for sensor mounting in hazardous locations. This setting compensates for the electrical characteristics of an Intrinsic Safety Barrier.
Defaults? Yes	Press ➡ 3 times to select <u>Y</u> es. Store to erase <u>all</u> user settings and return instrument to factory default setting.
Simul	The Output simulation function controls the 4-20mA output, digital display and control relays. Use it to simplify calibration of remote devices such as chart recorders or remote displays, and to test Relay set-points. Simulation digits are shown as a percentage of full scale. Use the ↑ and ↓ Arrow keys to simulate 0% (4mA), 100% (20mA), and increments of .05% (.008mA). Increments will automatically accelerate when the ↑ or ↓ is continuously pressed. In Range mode 0% = Min Range and 100% = Max Range and Display = Distance to simulated Range
4mA ADJ	Use to fine tune the 4mA and 20mA calibration of the 4-20mA output.
20mA ADJ	Adjustment range is +1mA to -1mA in 0.002mA steps <u>Important:</u> The 4-20mA output will be forced to 4mA and 20mA respectively during these adjustments.
New Password	Position cursor under digits and set new number between 00 and 99
Com 24 48 96 192	Speed of RS-232C transmission. Select 2400, 4800, 9600 or 19200 baud rate (must be set to match baud rate in 'PSL Remote' software and any modems used for serial communication).

INSTALLATION - SENSOR LOCATION
- Pump Station and Tank Level Applications

Each PSL includes a non-contacting ultrasonic sensor. The sensor must be installed in a position to obtain unobstructed echoes from the liquid or material being measured.

Mount the sensor away from pipes, ladders, or structural members which might cause continuous false echoes.

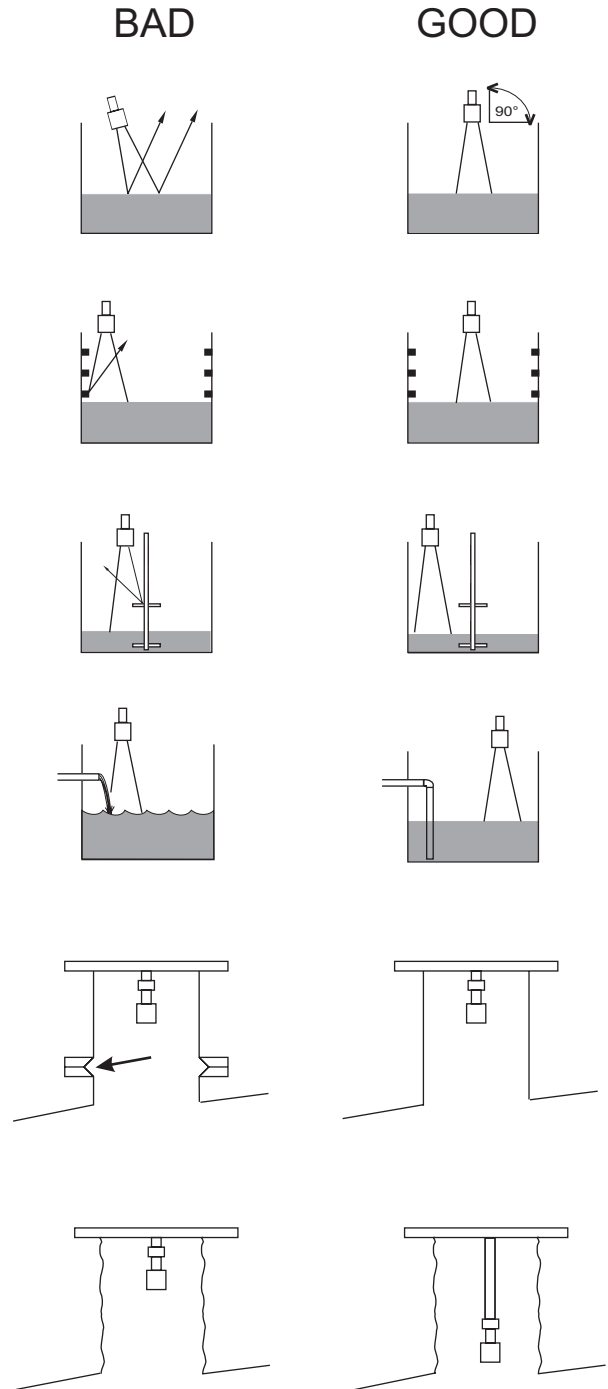

SENSOR MOUNTING LOCATION
- Pump Station and Tank Level/Inventory Applications

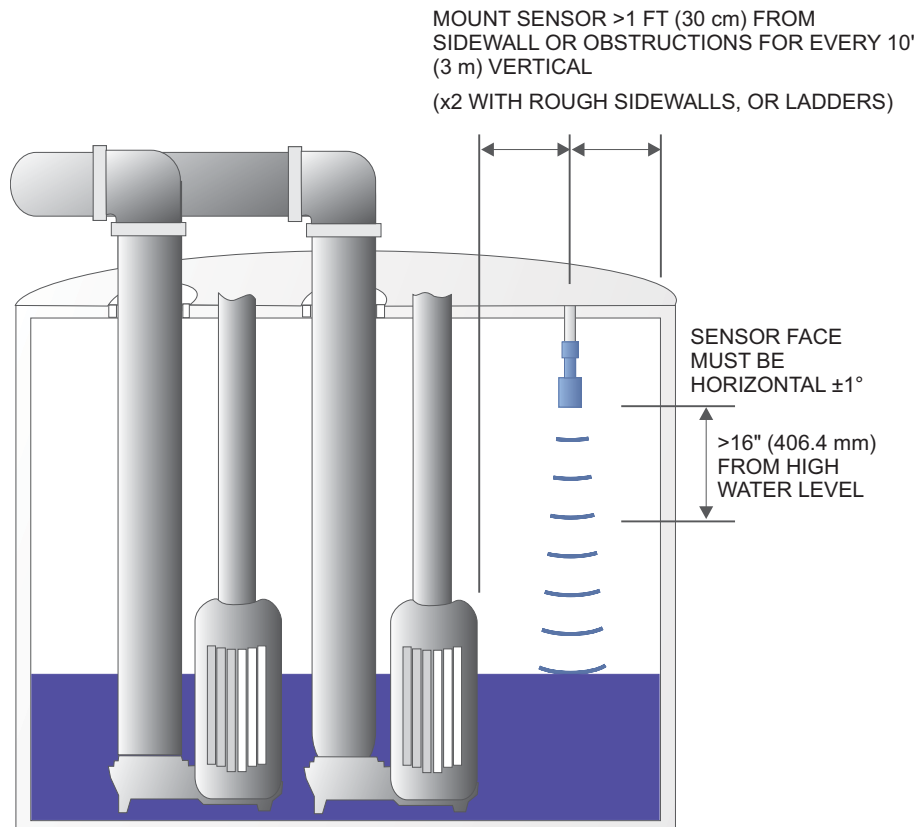

SENSOR MOUNTING

Each sensor is equipped with a 3/4 inch “isolation coupling” which **MUST** be used in your installation. A threaded nipple or length of conduit may be used to position the sensor at the desired height.

The sensor should be hand-tightened (like a light bulb) by turning the sensor stem only. **DO NOT** use a wrench and do not over tighten. **DO NOT** clamp the sensor below the isolation coupling.

Notes:

1. Use the 3/4" NPT "Isolation Coupling" supplied and *hand tighten* only. Do not clamp sensor body or stem.
2. Locate the sensor 1 ft (30 cm) from the sidewall or obstruction for every 10 ft (3 m) depth.
3. Do not mount in direct sunlight.
4. Extend sensor cable up to 500 ft (150 m) with RG62AU coaxial only.

FLANGE MOUNT

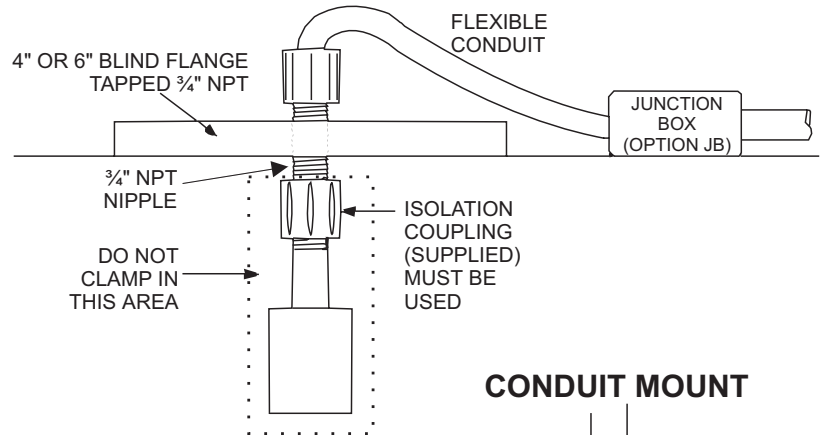

CROSS BAR MOUNT

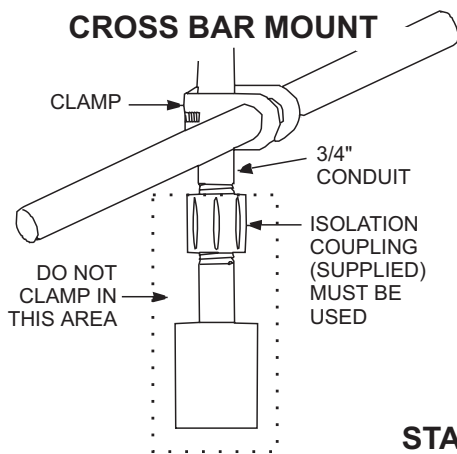

CONDUIT MOUNT

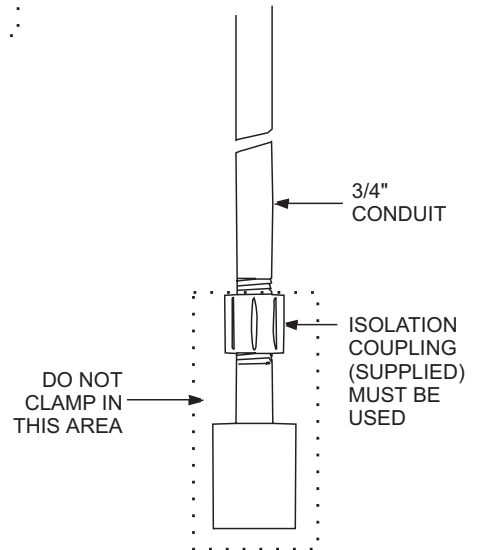

STAND PIPE MOUNT

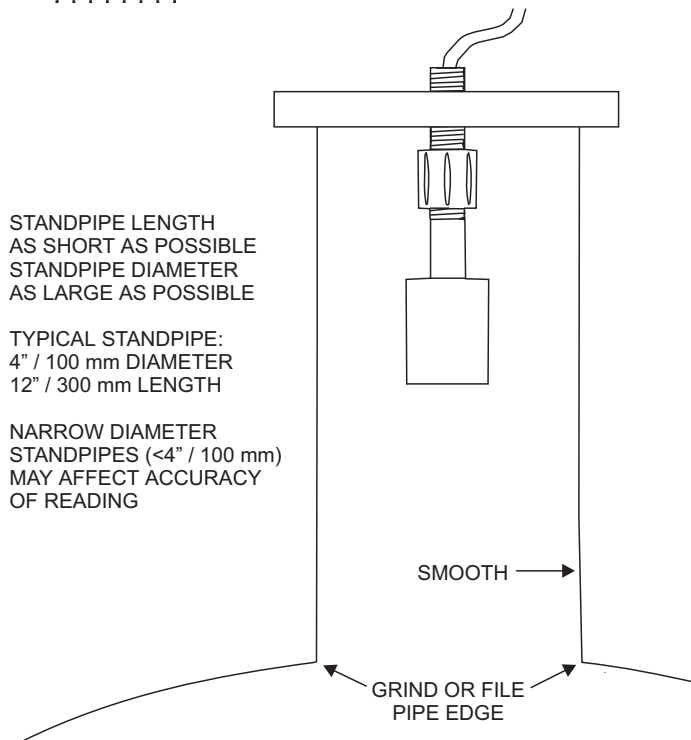

ANGLE MOUNT

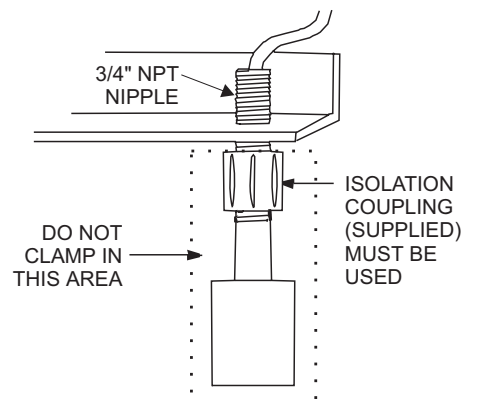

ENCLOSURE INSTALLATION

Locate the enclosure within 500 ft (150 m) of the sensor. It can be wall mounted with four mounting screws (supplied) or panel mounted with Option PM Panel Mounting Kit from Greyline Instruments. Avoid mounting the enclosure in direct sunlight to protect the electronics from damage due to overheating and condensate. In high humidity atmospheres, or where temperatures fall below freezing, Option TH Enclosure Heater and Thermostat is recommended. Seal conduit entries to prevent moisture from entering enclosure.

NEMA4X (IP66) WITH CLEAR COVER

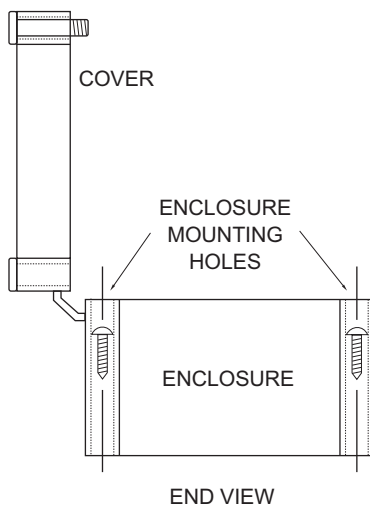

1. Open hinged enclosure cover.
2. Insert #8 screws and washers through the four enclosure mounting holes to secure enclosure to wall or mounting stand.
3. Close cover.

Additional conduit holes can be cut in the end of the enclosure when required. Use a hole saw or Greenlee-type hole cutter to cut the required holes.

Note: This non-metallic enclosure does not automatically provide grounding between conduit connections. Grounding must be provided as part of the installation. Ground in accordance with the requirements of the National Electrical Code. System grounding is provided by connecting grounding wires from all conduit entries to the steel mounting plate or another point which provides continuity.

ERROR/WARNING MESSAGES

"ECHO LOSS" (flashing)	No valid echoes received for 10 to 60 seconds. See FIELD TROUBLESHOOTING (F). To adjust the PSL's response time to Loss Of Echo see LOE Time in SPECIAL FUNCTIONS.
E: ILLEGAL SPAN	The value entered for MAX RG is the same or less than MIN RG. Maximum range <u>must</u> be greater than minimum range. (Note: to invert the scale and outputs, choose LEVEL instead of RANGE selection in the UNITS/MODE menu.) Max Rg - Min Rg must be ≥ 2 inches. Max Rg must be ≤ 102 ft (31.09 m)
E: ILLEGAL MINRG	The value entered for MINRG (Minimum Range) is less than 16" (1.333ft/40.64 cm). MINRG must be greater than or equal to 16" (40.64 cm). Minimum Range for optional PZ52T sensor must be greater than or equal to 24" (60.96 cm).
Err: ILLEGAL SETPOINTS	In level mode relay set points must be \leq span (MaxRg - MinRg). In range mode relay setpoint must be ≥ 1.33 ft (40.64 cm).
NORMAL / REVERSED SETPOINTS MIXED!	Relays selected for alternation have been calibrated in opposite modes. For alternation all Relays must be calibrated in the same mode: both Normal (ON setpoint > OFF setpoint) or both Reversed (ON setpoint < OFF setpoint).
TEMP * 23.5 C	* Indicates Temperature Compensation fault. Check sensor connections.
ECHO TOO CLOSE	Indicates that the level or target is above the calibrated maximum (too close to the sensor). * Indicates that the PSL has detected permanent interference (false echo) and has adjusted DAMP IN and RE TIME to 1 second for best performance. See FIELD TROUBLESHOOTING (A,C,D). * Also indicates a rate of level change that is too fast (Max = 1/2 inch/sec - 12.7 mm/sec). Decrease the DAMP IN and RE TIME values to 2 seconds.
!! SENSOR OPEN !	Instrument has detected sensor connection/cable Open.
! SENSOR SHORTED !	Instrument has detected sensor connection/cable Shorted.

FIELD TROUBLESHOOTING

<u>SYMPTOMS</u>	<u>CHECK</u>
Display - full scale	A
- zero	B
- erratic - random	C
- drifting up	D
- drifting down	E
ECHO LOSS prompt - flashing	F
Calibration Non-Linear	H

<u>SYMPTOMS</u>	<u>FAULTS</u>	<u>SOLUTIONS</u>
<i>Unit "See's" Wrong Target Due To:</i>		
A	- sensor cover not removed	- remove protective cover after installation
A,C,D,F	- sensor not aimed correctly	
A,D,F	- dust/dirt buildup on sensor	- clean <i>carefully</i> (do not scratch sensor face)
A,D,F	- condensation on sensor	- lower sensor - insulate sensor mounting location - increase M i n R g (CAL I B R A T I O N menu) by 1-3" / 2.5-7.5 cm - wipe sensor face and body with Rain-X
A,D	- sensor mounting stand pipe too long / - too narrow - dirty / - gasket intruding	- lower Sensor below stand pipe intrusion
C,E	- very turbulent level in tank	- increase REJ T I M E (CAL I B R A T I O N menu) - change tank fill method

<i>Unit Picks-Up Interference Due To:</i>		
A,C	- noise from high pressure fill	- install submerged fill pipe
A,D	- sensor coupling over tightened	- hand tighten only (like a light bulb)
A,D	- sensor coupling not used	- use coupling supplied
A	- echo Strength setting adjusted too high	- decrease Echo Strength setting
C	- other ultrasonic unit in close proximity	- synchronize

Electrical interference:

C	- sensor cable connections reversed	
C	- through sensor cable	- use properly <i>grounded</i> metal conduit
C	- sensor cable extended and junction not insulated	- use metal Junction Box
C	- through enclosure	- use metal enclosure
C	- through 4-20mA output cable	- use shielded twisted pair (shield to AC ground)

- C - wiring or installation close to variable speed drive or inverter
- follow V.S.D. manufacturer's instructions for Drive grounding, wiring and shielding

Unit Receives No Return Echo Due To:

- C,F,E - foam on liquid surface
- use stilling well. Increase ECHO STRENGTH setting
- B - target beyond MAXRG
- recalibrate
- F - sensor damaged
- remove sensor from mounting and aim at a flat, stable target to test

Wiring Problems Due To Sensor Cable:

- A,C,F, - open circuit
- check connections/continuity (8850 to 12700 ohms max./-30°C to +70°C)
- B,F - short circuit
- check connections/continuity (8850 ohms min.)
- F - too long (max 500 ft., 150 m)
- C - bundled/run in conduit with power cable
- C - sensor ground shorted to conduit/enclosure
- insulate
- A - extended with wrong type of wire
- use RG62A/U coaxial
- C - close to high voltage/large motors
- C - AC chassis/ground missing on instrument power connections

Non-Linearity Due To:

- H - vapour
- dissipate fumes, Calibration in-situ
- H - zero not set accurately
- see "Zero Positioning of Sensor"

Fuse Replacement

1. Turn OFF power
2. Loosen 2 Phillips bottom screws and remove Power Supply Module from the enclosure.
3. Locate fuse on Power Supply Board
4. Replace fuse with 2 Amp/250V, 5 x 20mm fuse
5. Reinstall Power Supply Module in the enclosure.

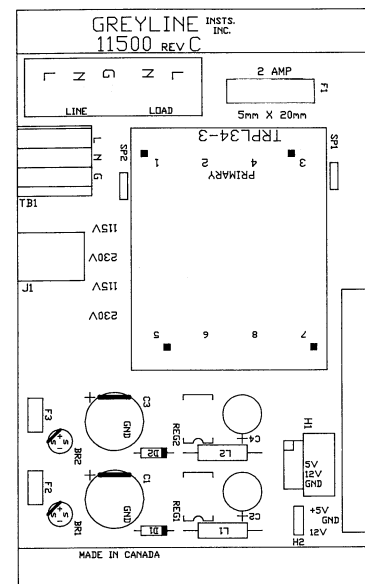

INSTALLATION CONSIDERATIONS IN NOISY ENVIRONMENTS

Greyline's instruments are designed with a high degree of noise immunity for use in industrial environments. Noise interference can still occur if certain minimal considerations are not adhered to when installing the equipment.

Noise

When relay contacts are used to switch inductive loads, such as auxiliary relays or solenoids, extremely large voltage spikes can be generated when the relay contact opens producing what is known as Radio-Frequency Interference or "RFI" or just "noise".

These voltage spikes can also be coupled from power lines that are powering equipment that contains S.C.R. circuitry such as VSD controllers, or lines that are actuating AC or DC solenoids or actuators. There are three major ways that noise spikes can enter the instrument.

1. Via the AC power input lines.
2. Via the Sensor input line.
3. Via the output lines (relay connections and 4-20mA output)

Symptoms of RFI produced by relay activation

If the instrument shows the following symptoms suspect RFI.

- The Alphanumeric display (bottom display) blinks continuously as if power was being turned off and on (i.e instrument resets continuously).
- Keypad does not respond or instrument resets to run mode from inside the menu.
- The instrument calibration is lost.
- The message "MEM CORRUPTED" is shown.
- Relays trip erratically.
- Both digital displays go blank as if power was OFF.

Symptoms of noise on sensor input and/or 4-20mA lines

- Instruments readings are erratic or high when actual value is low
- The Alphanumeric display (bottom display) blinks continuously as if power was being turned off and on i.e instrument resets continuously.
- Instrument "beeps" intermittently even if the Keypad is not pressed.

Avoiding noise problems

1. It is recommended that electronic instruments be connected to a relatively clean AC power source. Use an AC power filter or isolation transformer if necessary.
2. The sensor input line and the control lines (AC or DC) should not be run in the same conduit . The sensor input should be separated from wires going to inductive loads such as motors, solenoids, relays and contactors. For best results run the sensor wire in a separate metal conduit. A two-conductor shielded cable is recommended for the 4-20mA output, the shield should be connected to chassis ground at the instrument only.
3. For the relay connections, one of most overlooked sources of trouble, noise suppressors are recommended. Also known as “snubbers” these devices will limit the large spikes produced when the relay opens, stopping the RFI and also protecting the relay contacts from degrading.

NOISE SUPPRESSION ON RELAY OUTPUT

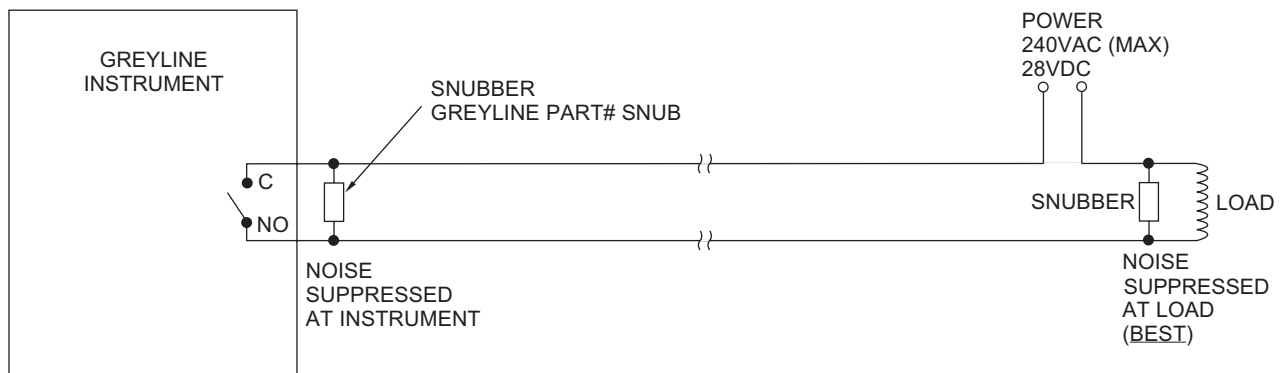

APPLICATIONS HOTLINE

For applications assistance, advice or information on any Greyline Instrument contact your Sales Representative, write to Greyline or phone the Applications Hotline below:

United States: Tel: 315-788-9500 Fax: 315-764-0419
Canada: Tel: 613-938-8956 Fax: 613-938-4857
Toll Free: 888-473-9546
Email: info@greyline.com
Web Site: <http://www.greyline.com>

Greyline Instruments Inc.

Canada
16456 Sixsmith Drive
Long Sault, Ont. K0C 1P0

USA:
105 Water Street
Massena, NY 13662

PRODUCT RETURN PROCEDURE

Instruments may be returned to Greyline for service or warranty repair.

1 Obtain an RMA Number from Greyline -

Before shipping a product to the factory please contact Greyline by telephone, fax or email to obtain an RMA number (Returned Merchandise Authorization). This ensures fast service and correct billing or credit.

When you contact Greyline please have the following information available:

1. Model number / Software Version
2. Serial number
3. Date of Purchase
4. Reason for return (description of fault or modification required)
5. Your name, company name, address and phone number

2 Clean the Sensor/Product -

Important: unclean products will not be serviced and will be returned to the sender at their expense.

1. Rinse sensor and cable to remove debris.
2. If the sensor has been exposed to sewage, immerse both sensor and cable in a solution of 1 part household bleach (Javex, Clorox etc.) to 20 parts water for 5 minutes. Important: do not immerse open end of sensor cable.
3. Dry with paper towels and pack sensor and cable in a sealed plastic bag.
4. Wipe the outside of the enclosure to remove dirt or deposits.
5. Return to Greyline for service.

3 Ship to Greyline -

After obtaining an RMA number please ship the product to the appropriate address below:

*Canadian and International
Customers:*

Greyline Instruments Inc.
16456 Sixsmith Drive
Long Sault, Ont. K0C 1P0

RMA#

USA

Customers:

Greyline Instruments Inc.
204 150th Avenue
Madeira Beach, FL 33708

RMA#

LIMITED WARRANTY

Greyline Instruments warrants, to the original purchaser, its products to be free from defects in material and workmanship for a period of one year from date of invoice. Greyline will replace or repair, free of charge, any Greyline product if it has been proven to be defective within the warranty period. This warranty does not cover any expenses incurred in the removal and re-installation of the product.

If a product manufactured by Greyline should prove defective within the first year, return it freight prepaid to Greyline Instruments along with a copy of your invoice.

This warranty does not cover damages due to improper installation or handling, acts of nature, or unauthorized service. Modifications to or tampering with any part shall void this warranty. This warranty does not cover any equipment used in connection with the product or consequential damages due to a defect in the product.

All implied warranties are limited to the duration of this warranty. This is the complete warranty by Greyline and no other warranty is valid against Greyline. Some states do not allow limitations on how long an implied warranty lasts or limitation of incidental or consequential damages, so the above limitations or exclusions may not apply to you.

This warranty gives you specific legal rights, and you may also have other rights which vary from state to state.

Greyline Instruments Inc.

APPENDIX A - OPTIONS

**EXTRA SENSOR CABLE
(OPTION XC)**

Each Greyline PSL includes 25 ft. (7.6m) RG62AU coaxial cable. Additional RG62AU coaxial cable and Cable Junction Box (Option JB) may be ordered, or the cable may be spliced and extended up to 500 ft (152m) as required during installation. No adjustment is required when the sensor cable is extended or shortened. Use only RG62AU (or RG62U) coaxial cable which is available from Greyline Instruments or your local distributor. Nominal impedance of RG62AU cable is 93 ohms.

Extended sensor cable must be installed in metal conduit to prevent interference. Recommended installation with a metal junction box is illustrated below:

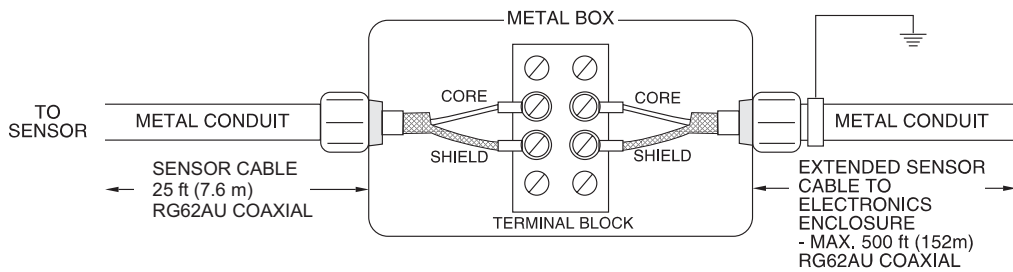

Note: Optional Watertight steel NEMA4 Junction Boxes with terminal strips (Option JB) are available from Greyline Instruments.

**DIMENSIONS
OPTION JB - JUNCTION BOX**

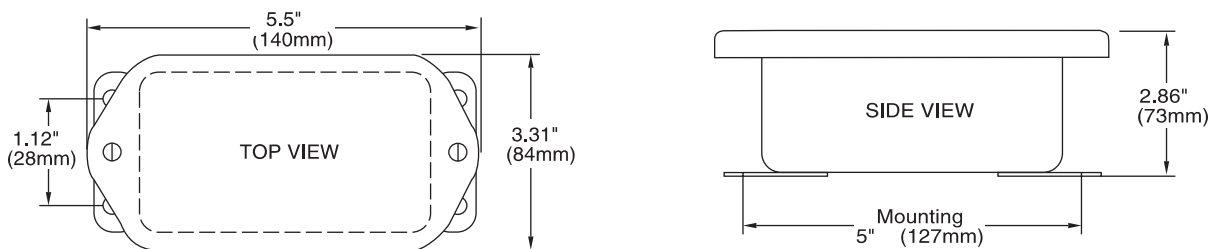

SENSOR INTRINSIC SAFETY - OPTION ISB

SENSOR MODELS PZ34/PZ32T/PZ32TE/PZ52T/PZ12 (with built-in temperature compensation)

When connected through an Intrinsic Safety Barrier, the Greyline PZ32T and PZ32TE sensors are CSA certified for installation in a hazardous location rated:

- Class I, Groups C,D
- Class II, Groups E, F and G
- Class III

Intrinsic Safety Barriers may be ordered with the Greyline instrument and are supplied mounted in the Greyline instrument enclosure. Replacement barrier fuses (Part No. ISB-011239) may be purchased separately. Barriers must be installed in the sensor cable between the safe and hazardous locations, and must be mounted in either the safe or Div. 2 area. Barriers may be plate, busbar or rail mounted.

Intrinsic Safety Barrier Specifications: Certified, rated 17.5V max, 95 ohms min. (Recommended: Stahl Model 9001/02-175-200-10).

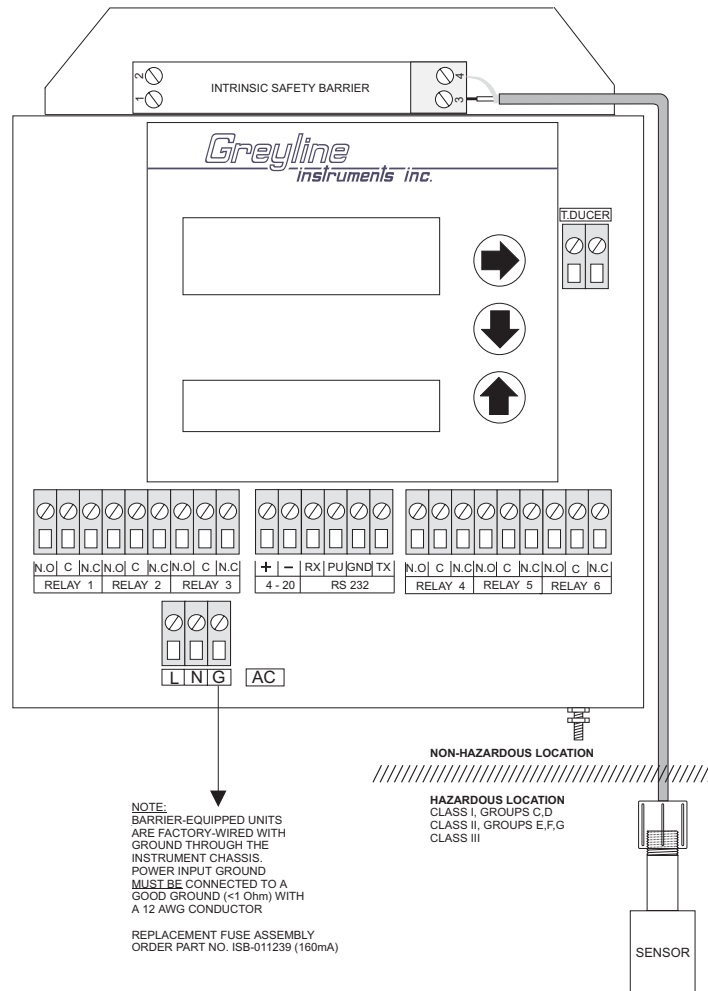

ENCLOSURE HEATER AND THERMOSTAT - Option TH

Instruments can be factory-equipped with an Enclosure Heater and Thermostat. The Thermostat is factory set to turn ON at 40°F (4.5°C) and OFF at 60°F (15.5°C). Power consumption is 15 Watts.

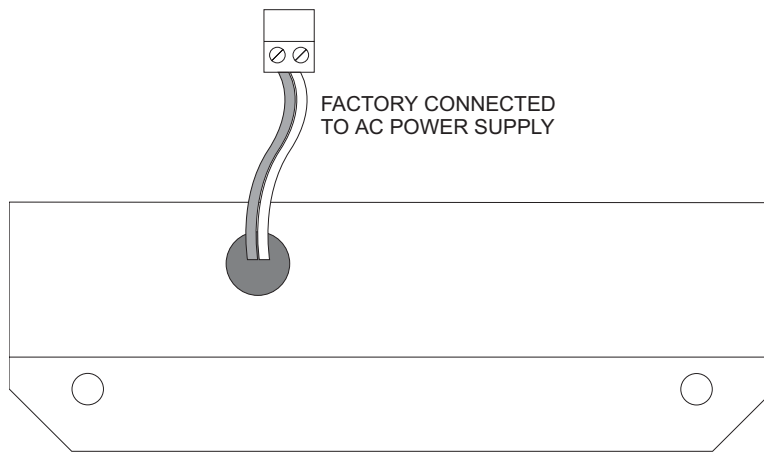

**POWER INPUT OPTION
12VDC OR 24VDC**

PSL Level + Flow Monitors may be ordered factory-configured for 12VDC, or 24VDC power input.

QUICK BENCH TEST:

Connect Sensor as shown below, then Power. When properly connected a soft clicking can be heard from the sensor and figures will show on the large LCD display. Test operation of the PSL by holding the sensor steadily and aiming at a flat, stable target 16 to 28" (406.4 to 711 mm) away from the end of the sensor. Allow a few seconds for the PSL to lock onto the target before displaying its distance. The PSL will now display Range in ft or cm (factory calibration).

CONNECTIONS:

POWER INPUT: Connect only 12VDC/0.5 Amps to the + and - terminals for units marked 12V, or 24VDC/0.5 Amps for units marked 24VDC. The Power Input GND must be connected to the nearest Ground pole. A 1 amp fuse in line is recommended. Power Consumption is 6.75 W continuous.

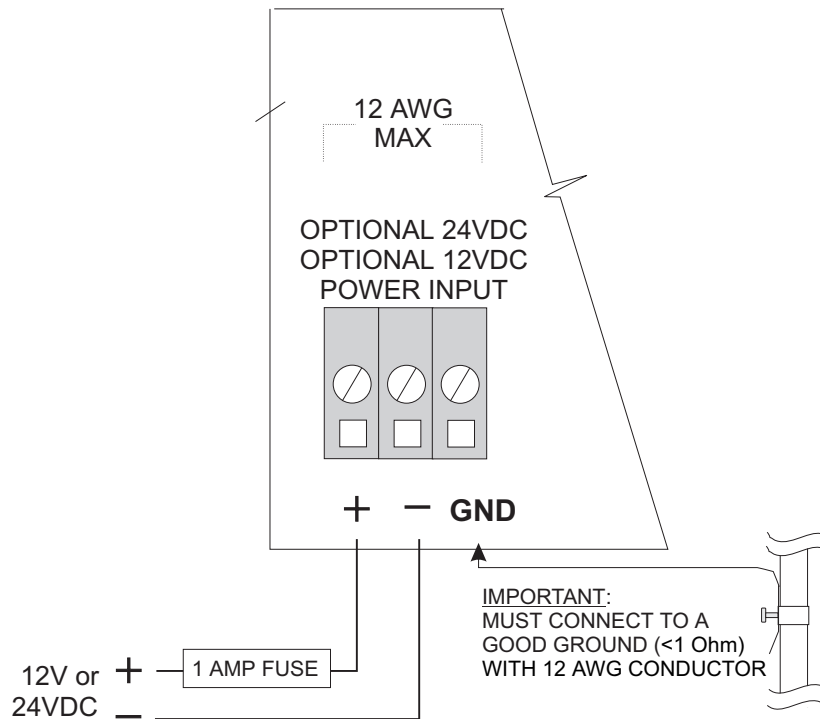

RS485 SERIAL OUTPUT
(Replaces standard RS232 Output)

Permits serial communication on long wire lengths up to 4000 ft. (1220 m). Use for PSL to PC communication only (not for multidrop RS485 networking).

Format: 8 Bits, 1 Stop Bit, No Parity. (Baud rate may be changed under the SPECIAL FUNCTIONS menu. Factory default is 19200 baud).

Use shielded, 4-conductor cable (Greyline cable option SC-18AWG recommended). Connect the cable shield to Ground at the PSL electronics enclosure and *do not* connect to Ground at the other end.

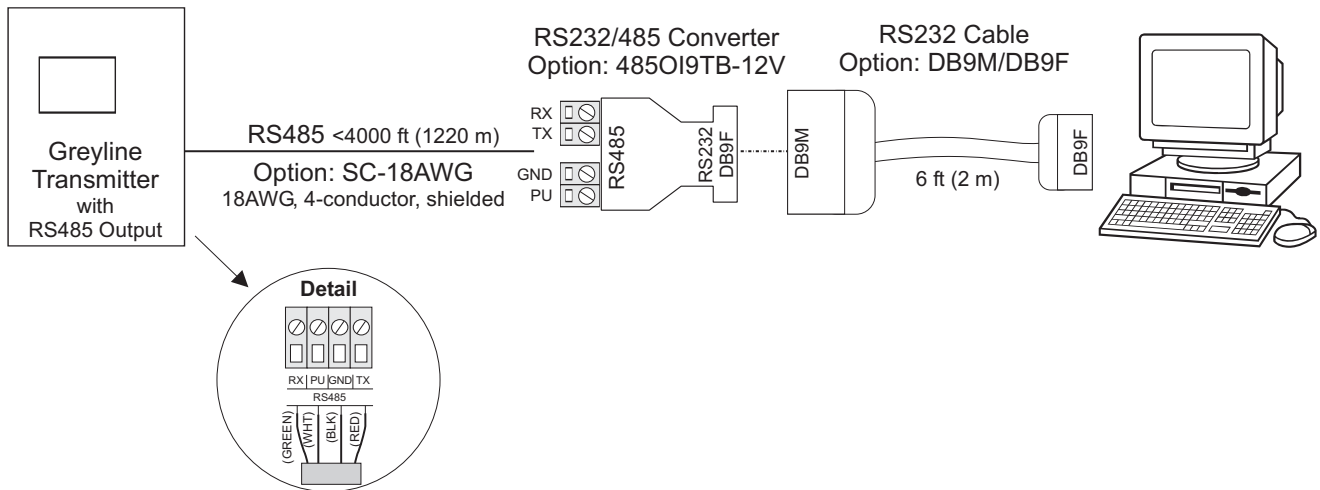

Configure the Greyline software program for RS485 communications. Under the Communications / Connection Setup menu, select 'Connected to a Greyline 485OI-12V adaptor'.

485OI9TB-12V
RS232/RS485 Converter

Use with optional RS485 output for connection to a PC computer or modem.

- Optically isolates and protects your computer's RS232 port
- Terminal block for RS485 connections
- Operates from 2400 up to 19.2K baud



DB9M/DB9F - RS232 Cable
Connects RS232/485 Converter to a PC

Cable length 6 ft. (2 m) with DB9M and DB9F connectors.

ENCLOSURE SUNSCREEN - OPTION SCR

Do not mount instrument electronics in direct sunlight. Overheating will reduce the life of electronic components and condensate may form during the heat/cool cycles and cause electrical shorts.

Note:

Exposure to direct sunlight can cause overheating and moisture condensation which will reduce the operating life of electronics.

Protect Instruments from direct sunlight with this iridite finished aluminum sun screen (Greyline Option SCR).

Seal conduit entries with caulking compound to further reduce moisture condensation.

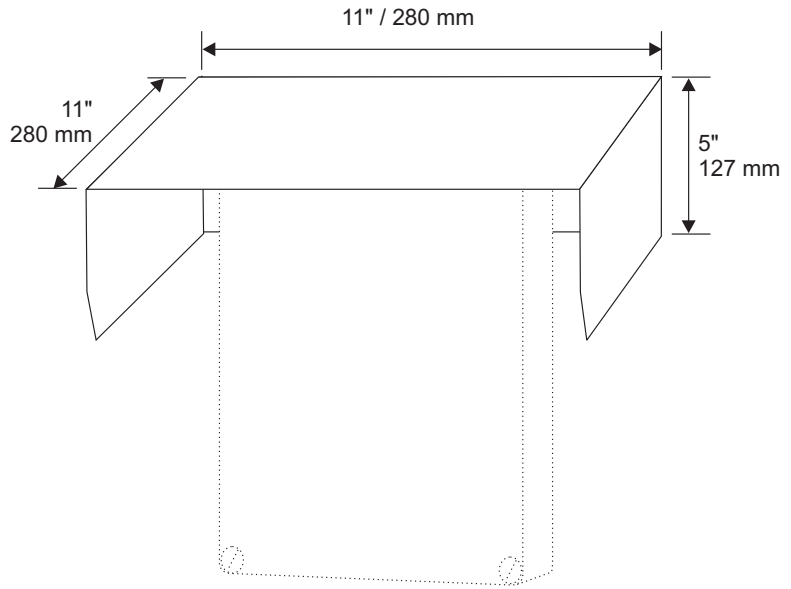

SENSOR SUNSCREEN - OPTION PZS

INSTALLATION

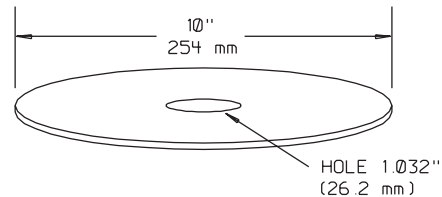
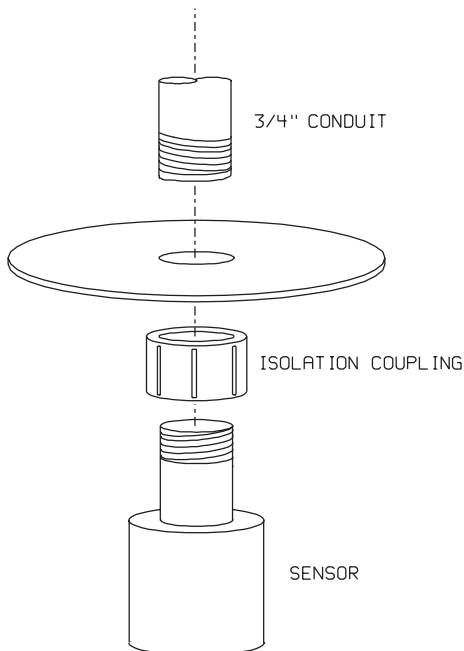

MATERIAL:
1/16" ANODIZED ALUMINUM

NOTE:
USE WHEN SENSOR IS INSTALLED IN DIRECT SUNLIGHT.

APPENDIX B - APPLICATIONS BACKGROUND

Conditions in the tank or channel where the ultrasonic sensor is installed can affect the performance, range and accuracy of the system. The following notes are for general reference. Contact Greyline Instruments or your local representative for specific information on your application.

FOAM - Solid or dense surfaces such as a smooth liquid surface will give the best echos in an ultrasonic level measuring system. Foam acts as a sound insulator and may eliminate, or reduce the strength of an echo. Measurement range may be reduced in a system where foam is present. Ultrasonics are not recommended where thick dense foam is continually present. Thin layers of light foam (½ in. or less) can generally be disregarded. Use a stilling well in open channel applications.

LIQUIDS - The PSL is ideal to monitor tank liquid level or inventory. Caustic, corrosive or very viscous liquids can be monitored without contacting the liquid.

SOLIDS - The PSL will measure most granular material and powders as well as liquids. Powders will not generally provide the same echo strength as liquids. Therefore maximum expected range should be reduced to approximately 20 feet (6 m) for powders. There are many exceptions to this rule and installation of a test system is recommended when in doubt.

DUST - Any obstructions to the sound will affect performance of the system. In silo's where heavy concentrations of dust are expected ultrasonics may not work. Where moderate dust is encountered care should be taken to mount the sensor in a position where dust accumulation will be minimized and where the sensor can be cleaned if necessary.

SENSOR TEMPERATURE - The standard sensor model PZ34 supplied with each Pump Station Level Controller includes a built-in temperature sensor. The PSL automatically compensates for temperature fluctuations to retain high accuracy. Note the operating temperature ranges listed in the product specifications section. Do not exceed the sensor temperature ratings or damage may occur.

ELECTRONICS TEMPERATURE - Note operating temperature ranges listed in the product specifications. Temperatures higher than the maximum shown can reduce the operating life of the electronics. Moisture condensation from those temperatures below the range shown can also damage electronics components. In cold or outdoor environments the optional factory-installed enclosure heater and thermostat is recommended.

NOISE - Because the PSL's sensor operates at high sound frequency, regular process noise or vibration will not affect the system. Sensors installed in close proximity to one another in the same tank may "cross-talk" and should be synchronized.

VAPOUR - May affect but it can be compensated for by calibration in-situ. Severe vapour stratification can cause false echos. Variable vapour cannot be compensated.

CHEMICAL COMPATIBILITY - The PSL's Sensor is constructed of very durable materials with broad compatibilities. Tank contents should be checked for their compatibility with PVC. An all-teflon sensor is available for corrosive applications.

CONVERSION GUIDE		
FROM	TO	MULTIPLY BY
US GALLONS	CUBIC FEET	0.1337
US GALLONS	IMPERIAL GALS	0.8327
US GALLONS	LITRES	3.785
US GALLONS	CUBIC METERS	0.003785
LITRES/SEC	GPM	15.85
LITRES	CUBIC METERS	0.001
BARRELS	US GALLONS	42
BARRELS	IMPERIAL GALS	34.9726
BARRELS	LITRES	158.9886
INCHES	MM	25.4
DEGREES F	DEGREES C	(°F-32) x 0.556
POUNDS	KILOGRAMS	0.453
PSI	BAR	0.0676
FOOT ²	METER ²	0.0929

VOLUME CALCULATION FOR ROUND TANKS: $3.142 \times R^2 \times H$

R = TANK RADIUS (½ TANK DIAMETER)

H = TANK HEIGHT

SPECIFICATIONS

- Electronics Enclosure:** Watertight, dust tight NEMA4X (IP 66) polycarbonate with a clear, shatter-proof face
- Accuracy:** ±0.25% of Range or 2 mm (0.08") whichever is greater
- Displays:** Level - large, 4 digit LCD; Menu/Reports/Status - 16 digit alphanumeric
- Calibration:** Level or Range mode in selectable units
- Programming:** Built-in, 3 button keypad, password-protected; or via RS232
- Power Input:** 100-130VAC, 50/60 Hz, (7.5 W max.)
Optional: 200-260VAC, 50/60 Hz, (7.5 W max.)
Optional: 12VDC or 24VDC (6.75 W max.)
- Outputs:** Isolated 4-20mA (1000 ohm), RS232 (cable and null-modem connector included)
- Control Relays:** 6 form 'C' dry contact Relays rated 5 amp SPDT; programmable level alarm and/or pump control modes, pump alternation/sequencing, failsafe/echo-loss, air temperature alarm
- Electrical Surge Protection:** Sensor, 4-20mA and AC power
- Operating Temperature:** Electronics: -5 to 140°F (-20 to 60°C).
- PC Software:** 'PSL Remote' for Windows - save calibrations to disk, Relay run-time reports, real-time monitoring with direct RS232 connection or through modems.

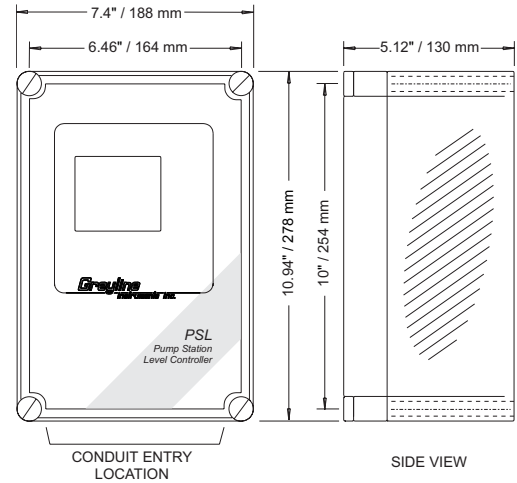

Standard Sensor PZ34

- Maximum Range:** 32 ft. (10 m)
- Minimum Range (Deadband):** 16" (406.4 mm)
- Operating Frequency:** 46 KHz
- Beam Angle:** 8°
- Temperature Compensation:** Automatic, continuous
- Operating Temperature:** -40° to 150°F (-40° to 65°C)
- Maximum Operating Pressure:** 20 psi (1.35 Bar)
- Exposed Materials:** PVC
- Sensor Mounting:** 3/4" NPT
- Maximum Cable Length:** 500 ft (152 m)
- Optional Hazardous Rating:** CSA rated Intrinsically Safe Class I, Groups C,D, Class II, Groups E,F,G with optional Intrinsic Safety Barrier.

Note: Max Range reduced to 25 ft (7.8 m) with ISB option.

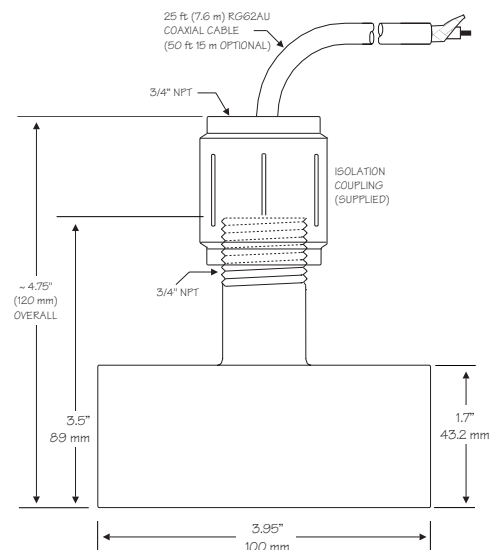

Optional PZ34T_F

- Maximum Range:** 32 ft. (10 m)
- Minimum Range (Deadband):** 16" (406.4 mm)
- Operating Frequency:** 46 KHz
- Beam Angle:** 8°
- Temperature Compensation:** Automatic, continuous
- Operating Temperature:** -40° to 150°F (-40° to 65°C)
- Maximum Operating Pressure:** 20 psi (1.35 Bar)
- Sensor Face:** Teflon
- Sensor Body:** PVC (not exposed to tank contents)
- Cable Length:** 25 ft. (7.6 m) continuous RG62AU coaxial Optional 50 ft. (15 m) continuous
- Maximum Cable Length:** 500 ft (152 m) RG62AU coaxial (splice)
- Hazardous Rating:** CSA rated Intrinsically Safe Class I, Groups C,D, Class II, Groups E,F,G with optional Intrinsic Safety Barrier.

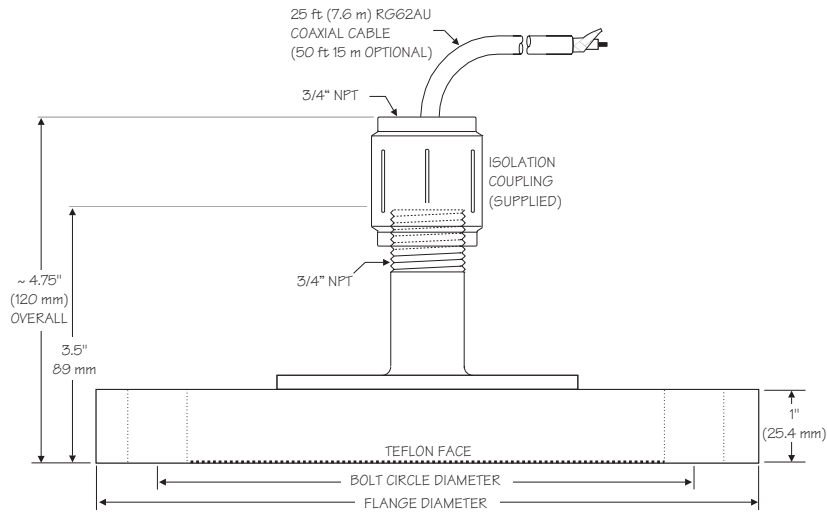

Optional Sensor PZ32T

- Maximum Range:** 32 ft. (10 m)
- Deadband (blanking):** Programmable, minimum 12" (305 mm)
- Beam Angle:** 8° at 3 DB
- Temperature Compensation:** Automatic, continuous
- Operating Frequency:** 42 KHz
- Exposed Materials:** PVC and Teflon
- Operating Temperature:** - 40° to 150°F (-40° to 65°C)
- Operating Pressure:** 20 psi (1.35 Bar) maximum
- Mounting:** 3/4" NPT (PVC isolation coupling supplied)
- Sensor Cable:** RG62AU coaxial, 25 ft. (7.6 m) standard with optional Intrinsic Safety Barrier: CSA, Class I,II,III, Div. I,II, Groups C,D,E,F,G
- Note:** Max Range reduced to 25 ft (7.6 m) with ISB option.

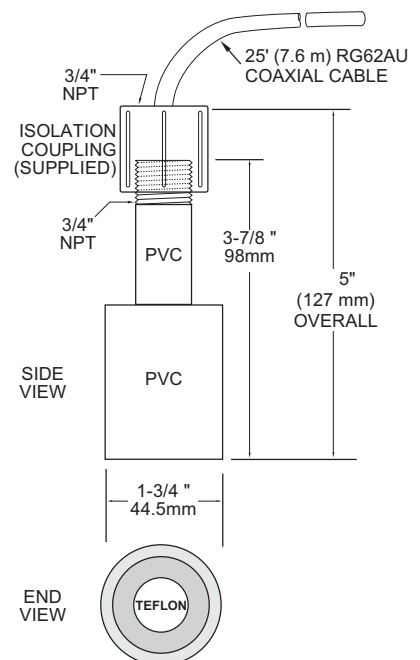

Optional Sensor PZ32TE

- Maximum Range:** 32 ft. (10 m)
- Deadband (blinking):** Programmable, minimum 12" (305 mm)
- Beam Angle:** 8° at 3 DB
- Temperature Compensation:** Automatic, continuous
- Operating Frequency:** 42 KHz
- Exposed Materials:** Teflon
- Operating Temperature:** -40° to 170°F (-40° to 76°C)
- Operating Pressure:** 20 psi (1.35 Bar) maximum
- Mounting:** 3/4" NPT (Teflon isolation coupling supplied)
- Sensor Cable:** RG62AU coaxial, 25 ft. (7.6 m) standard
- Hazardous Rating:** with optional Intrinsic Safety Barrier: CSA, Class I,II,III, Div. I,II, Groups C,D,E,F,G,
Note: Max Range reduced to 25 ft (7.6 m) with ISB option.

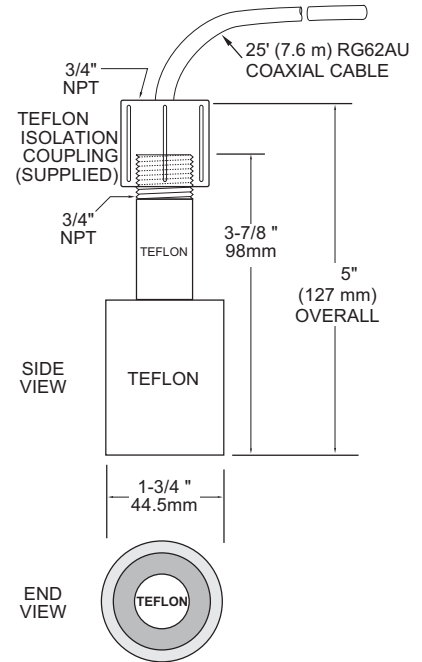

Optional Sensor PZ52T

- Maximum Range:** 50 ft. (15.6 m)
- Deadband (blinking):** Programmable, minimum 16" (406 mm)
- Beam Angle:** 8° at 3 DB
- Temperature Compensation:** Automatic, continuous
- Operating Frequency:** 40 KHz
- Exposed Materials:** PVC and Teflon
- Operating Temperature:** -40° to 150°F (-40° to 65°C)
- Operating Pressure:** 20 psi (1.35 Bar) maximum
- Mounting:** 3/4" NPT (Isolation Coupling supplied)
- Sensor Cable:** RG62AU coaxial, 50 ft. (15 m) standard
- Hazardous Rating:** with optional Intrinsic Safety Barrier: CSA, Class I,II,III, Div. I,II, Groups C,D,E,F,G,
Note: Max Range reduced to 32 ft (10 m) with ISB option.

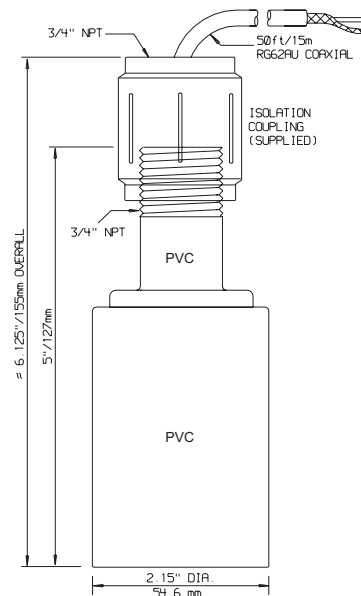

Optional Sensor PZ12

- Maximum Range:** 12 ft (3.66m)
- Minimum Range(Deadband):** 8" (203.2 mm)
- Operating Frequency:** 92 KHz
- Beam Angle:** 8°
- Operating Temperature:** -40° to 150°F (-40° to 65°C)
- Temperature Compensation:** Automatic, Continuous
- Max. Operating Pressure:** 20 psi (1.35 Bar)
- Sensor Face:** PVC
- Sensor Body:** PVC
- Mounting:** 3/4" NPT
- Cable Length:** 25 ft. (7.6 m) continuous RG62AU coaxial. Optional 50 ft. (15 m) continuous
- Max. Cable Length:** 500 ft. (152 m) RG62AU coaxial (splice)
- Hazardous Rating:** with optional Intrinsic Safety Barrier: CSA, Class I,II,III, Div. I,II, Groups C,D,E,F,G

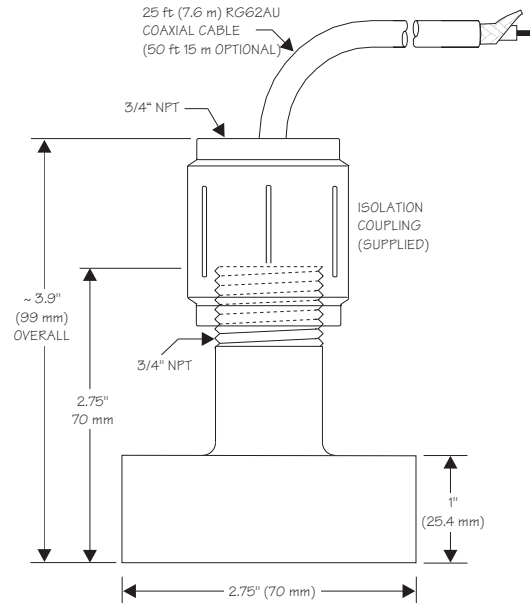

PSL - CALIBRATION RECORD

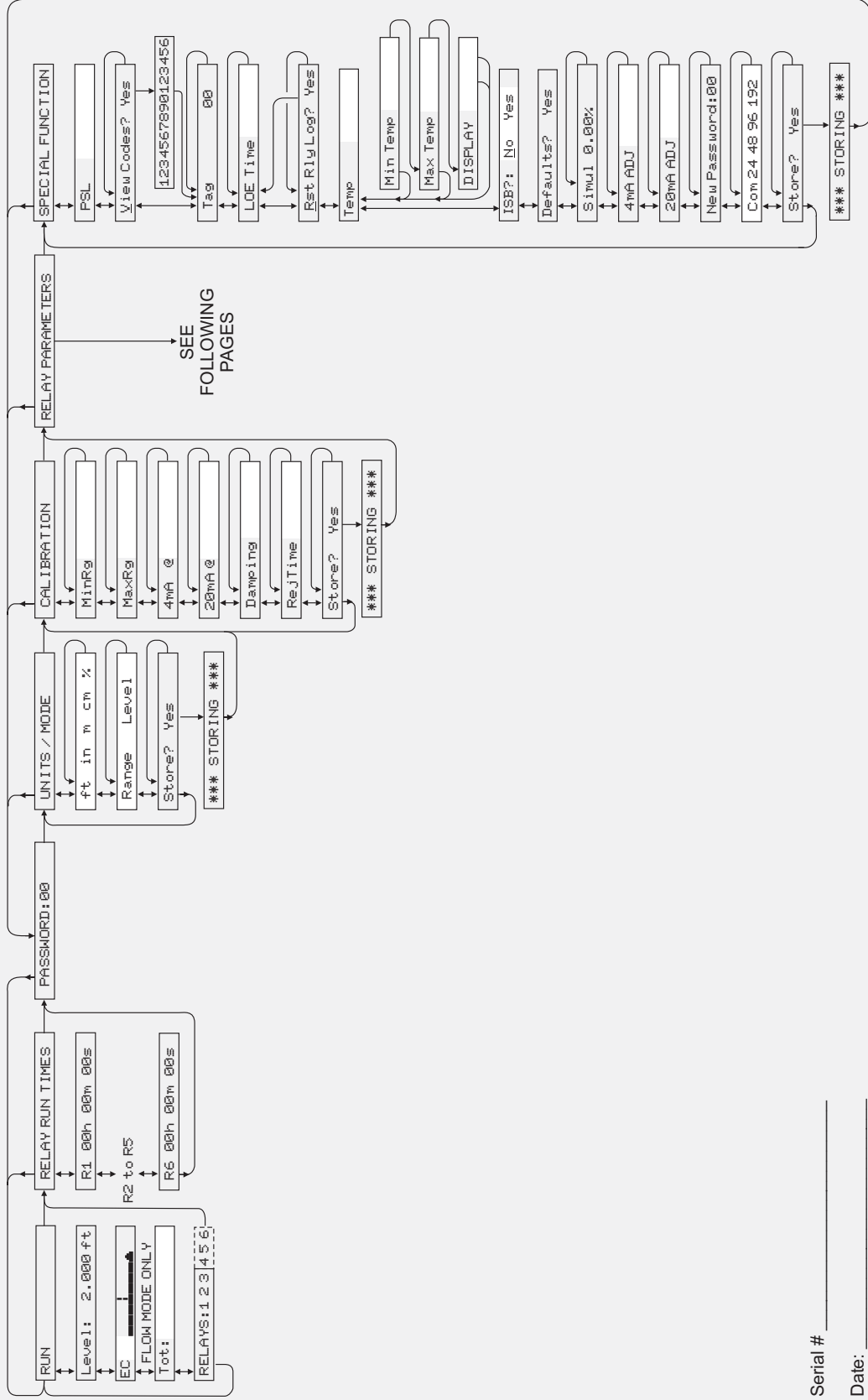

Serial # _____

Date: _____

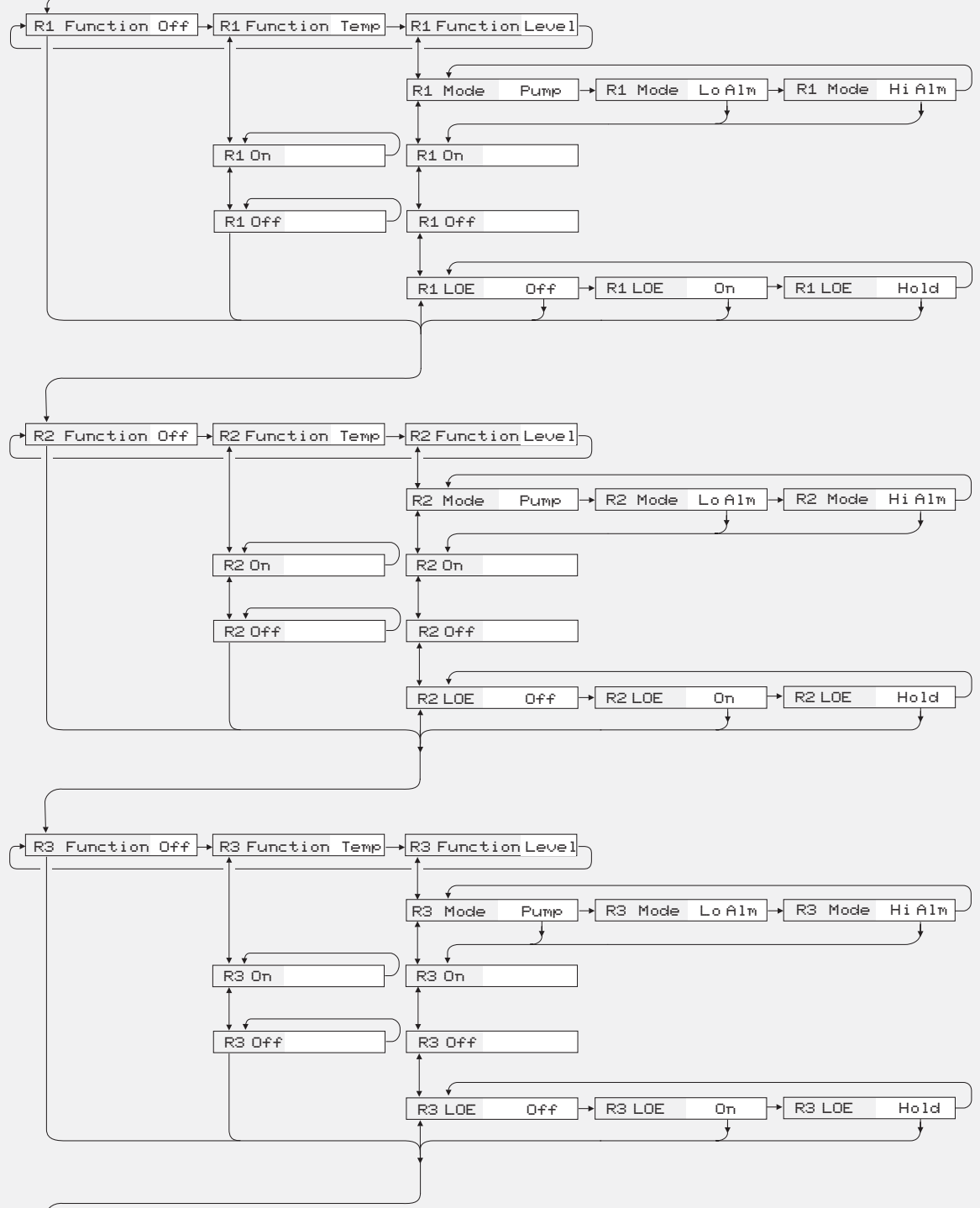

cont'd
next
page

